

REV	DATE	BY	DESCRIPTION
-	11-3-2013	PB_Admin	NEW VAULT, NEW REVISION. NOTHING CHANGED. OLD REV WAS C
A	20-12-2013	BS	SCREW CAP DESIGN CHANGED, NEW NUMBER (WITH O-RING) IS E0011495
B	17-11-2015	AvD	ITEM 1 CHANGED: E0044571 WAS E0011497

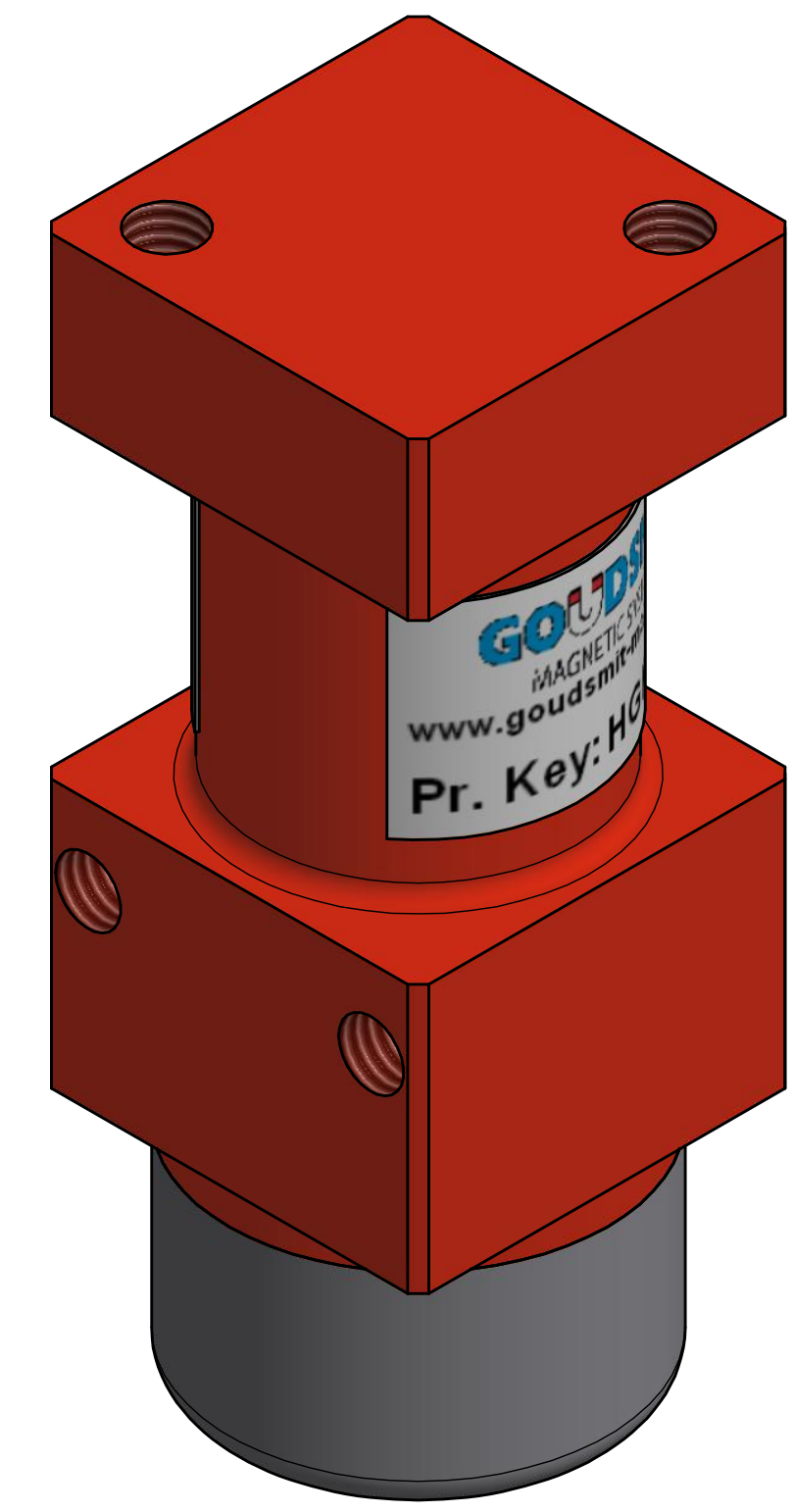
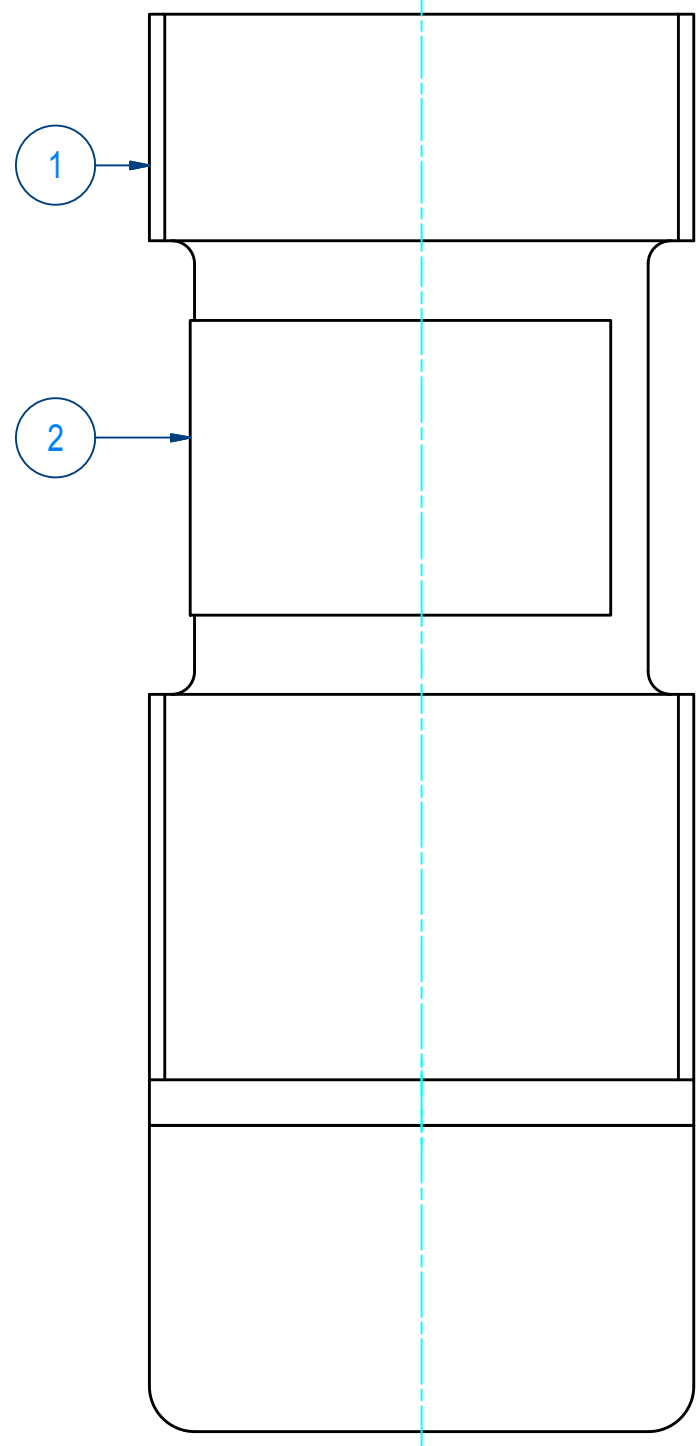
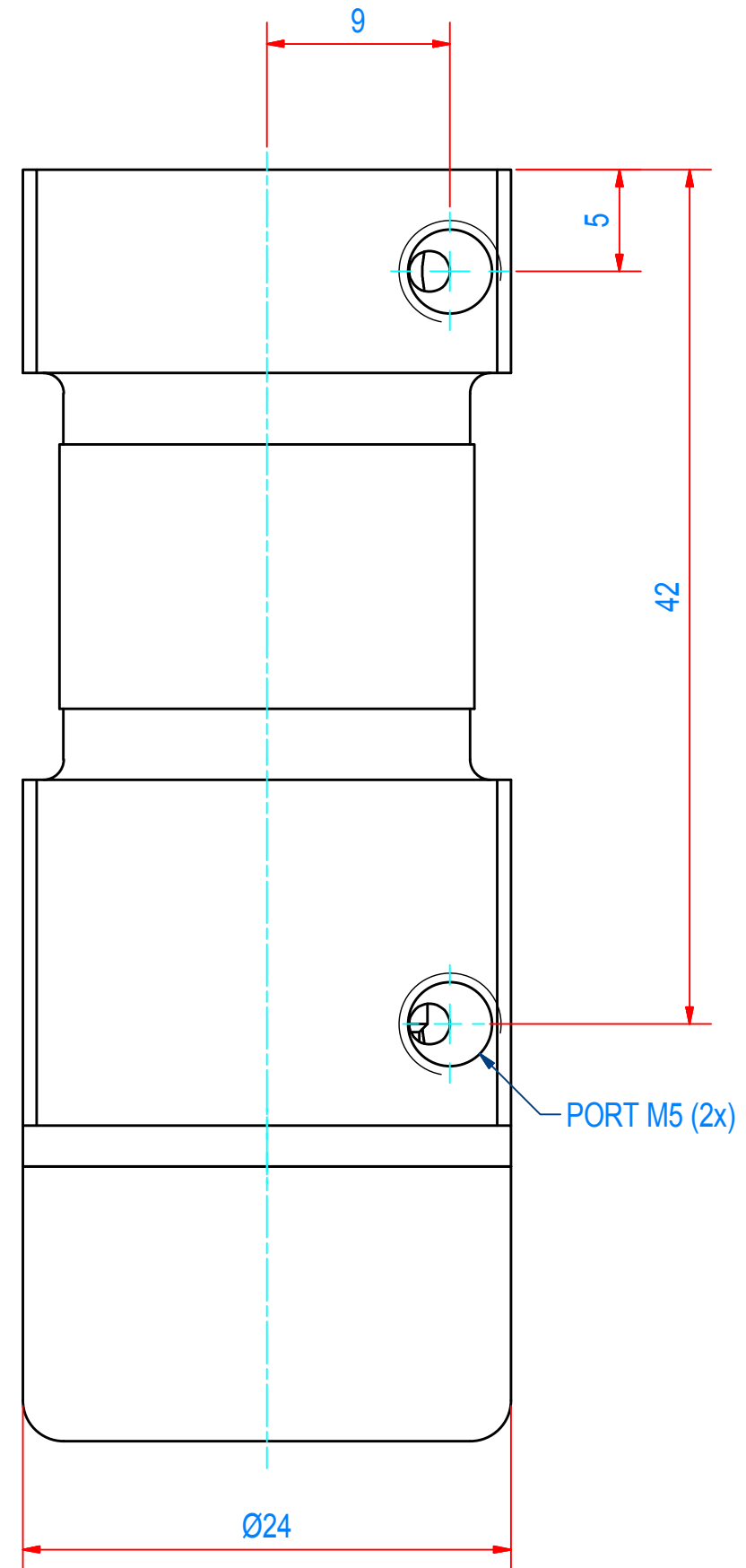
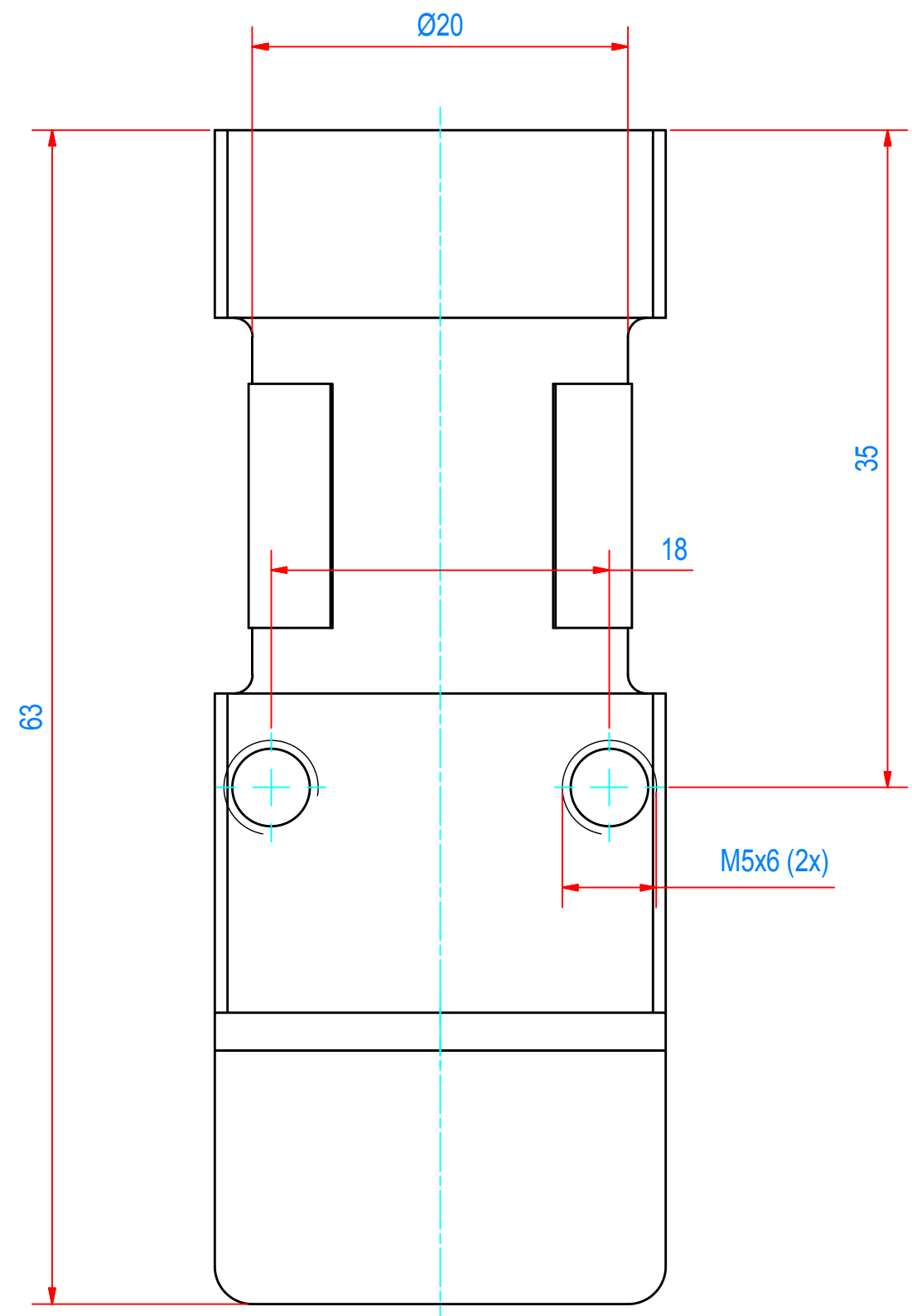
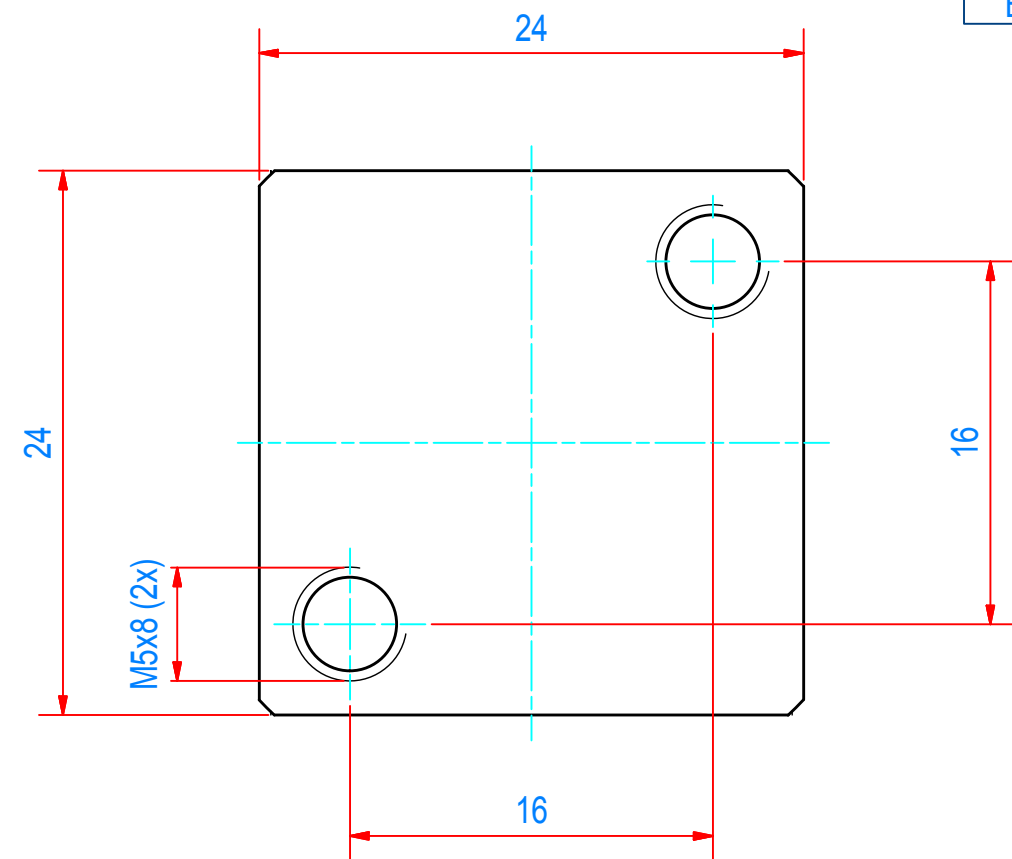

ITEM	QTY	PART NUMBER	DESCRIPTION	Dimensions	
2	1	E0037929	STICKER TPGC024078		
1	1	E0044571	MOUNTING ASSY TPGC024078		
RAW MAT.	QTY	MAT. NUMBER	MAT. DESCRIPTION	LENGTH (mm)	WIDTH (mm)
⊕	1				
Sheet:	A2	Extra info:	MAGNETIC GRIPPER	General tolerance:	ISO 2768 - mK
Drawn:	AvD	Weight (kg):	0,1	Drawn according:	ISO268; ISO1101; ISO2553
Date:	17-11-2015			Status:	Standard
Spare part:	False			Customer reference number:	
Quick search:	TPGC024			File number:	TPGC024078
Description:	HGR-SQ-024-FL-R-M-F			Part number:	TPGC024078
				Rev:	B
				Rev:	B