

REV	DATE	BY	DESCRIPTION
-	18-6-2013	BS	NEW VAULT, NOTHING CHANGED, IS EQUAL TO OLD REVISION A
A	16-11-2015	AvD	SCREW CAP AND PISTON CHANGED

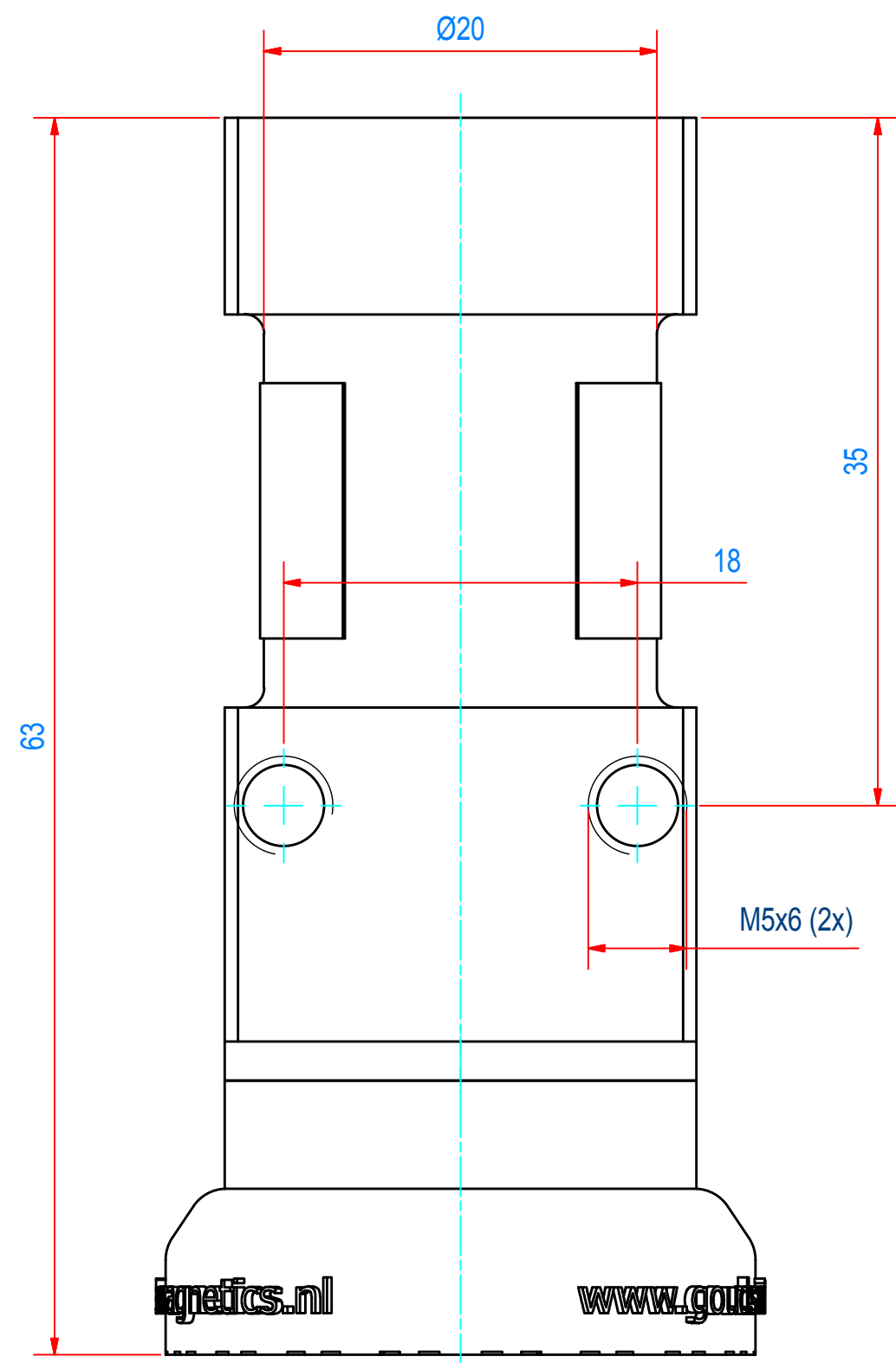
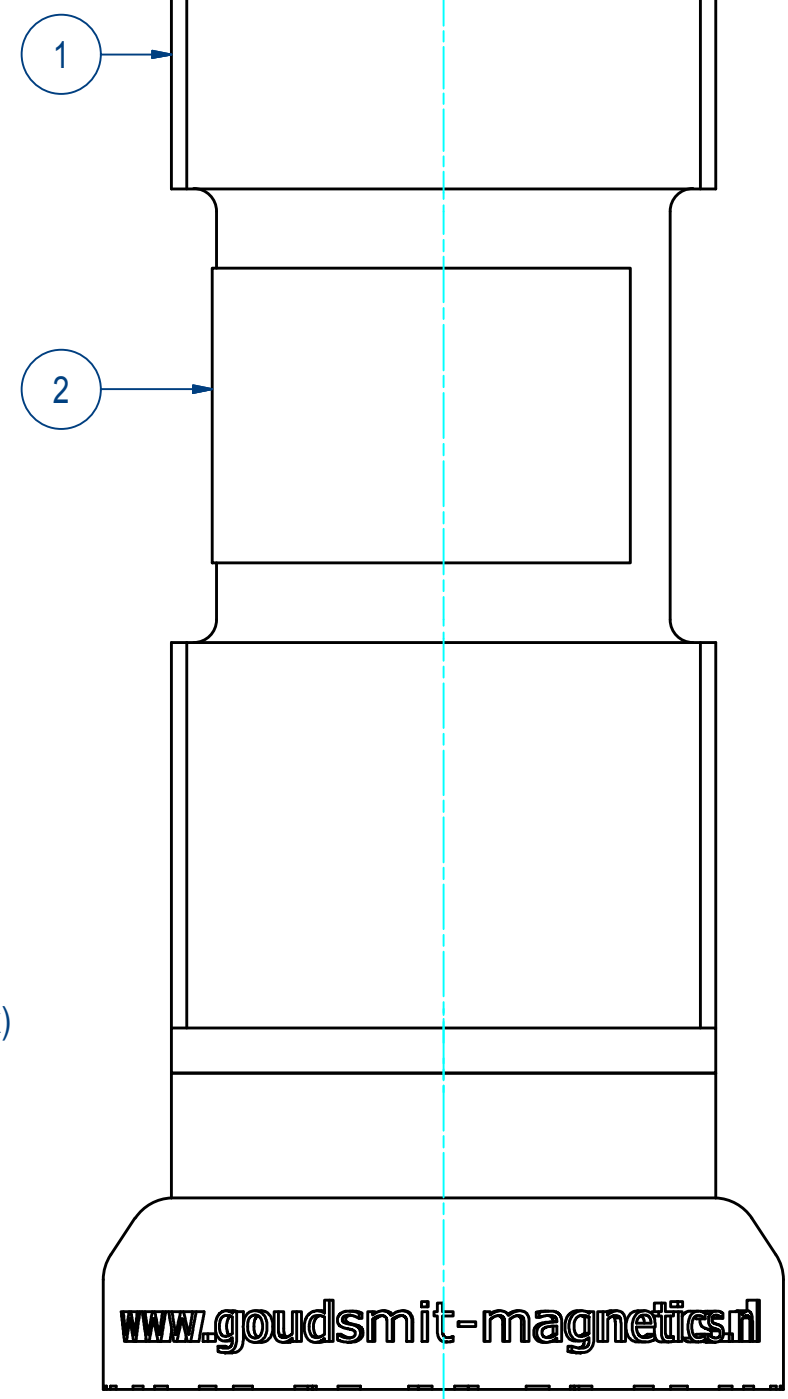
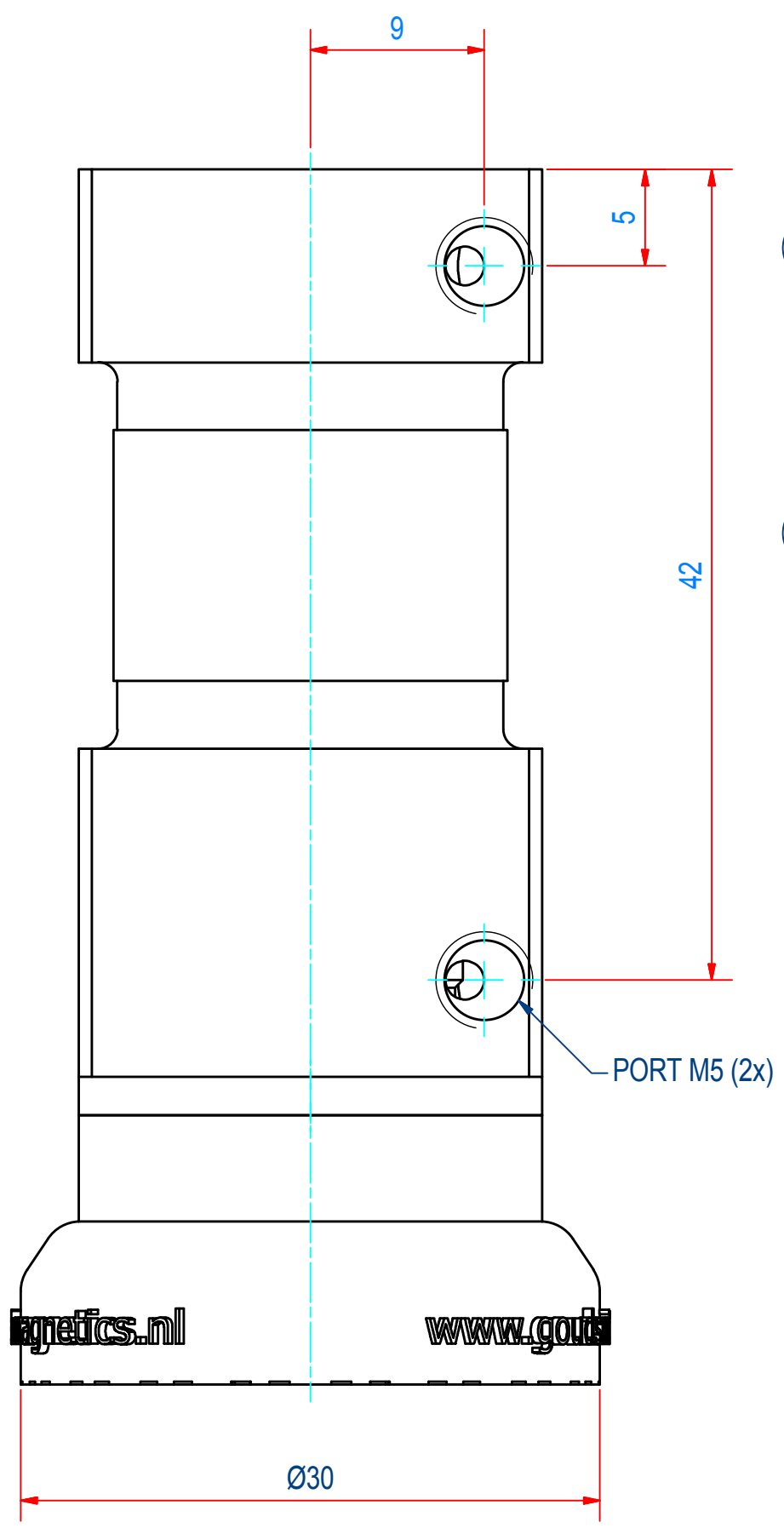
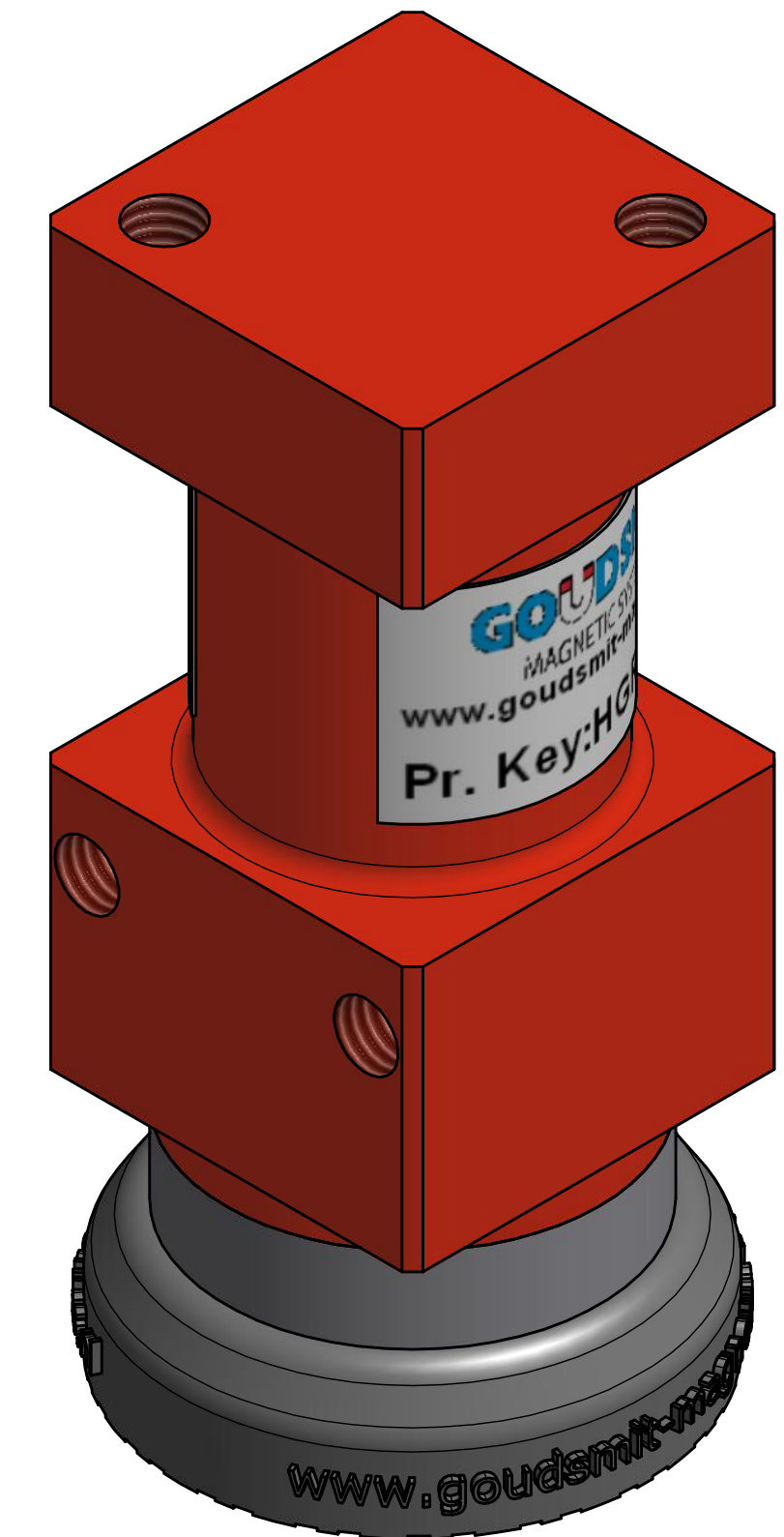
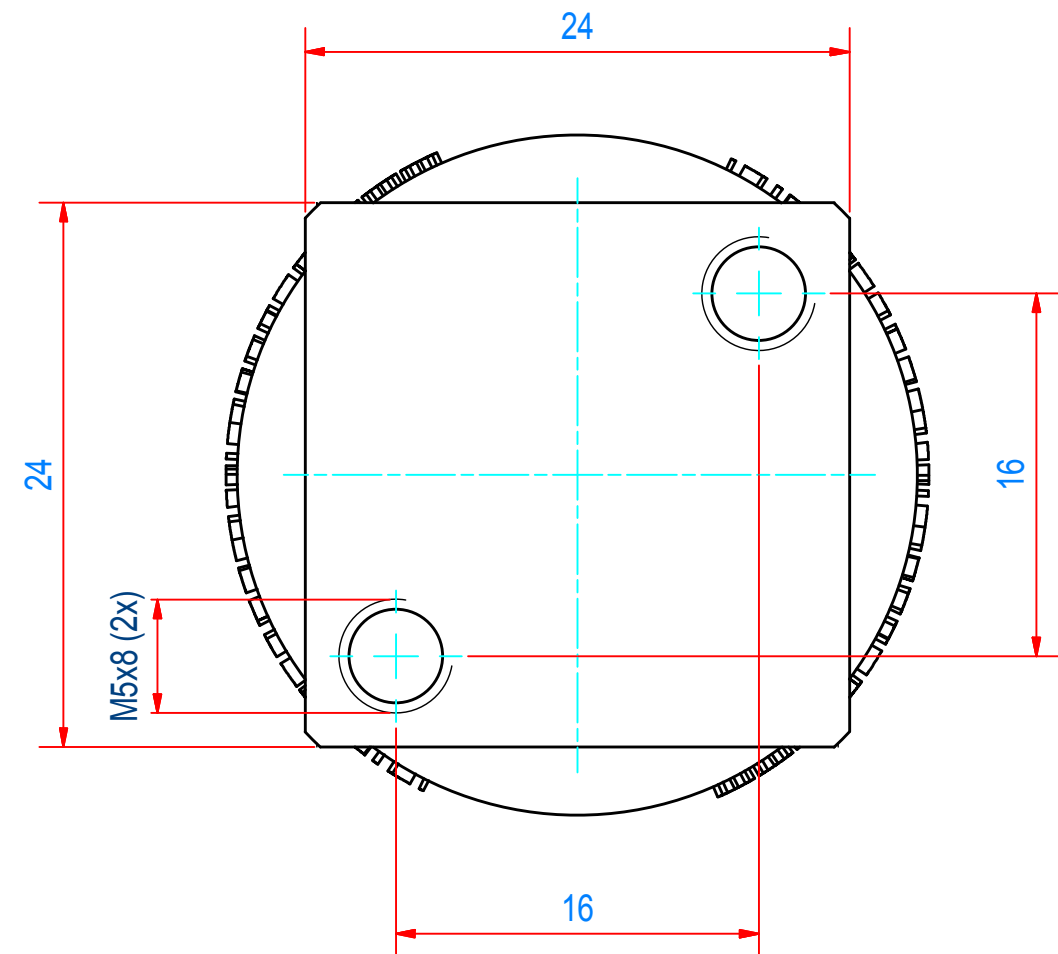

ITEM	QTY	PART NUMBER	DESCRIPTION	Dimensions
2	1	E0037935	STICKER TPGC024088	
1	1	A190252	MOUNTING ASSY TPGC024088	
RAW MAT.	1			
Sheet:	A2	Extra info:	General tolerance:	ISO 2768- mK
Drawn:	BS	Weight (kg): 0,1	Drawn according:	ISO268; ISO1101; ISO2553
Date:	18-6-2013		Status:	Standard
Spare part:	False		Customer reference number:	
Quick search:	TPGC024		File number:	TPGC024088
Description:	HGR-SQ-024-FP-R-M-F		Part number:	TPGC024088