

**NEXT STEP**  
AUTOMATION

(주)넥스텝

Tel. 053-604-3040 Fax. 053-604-3042  
Web.nstep.co.kr Mob.010-4488-3040

| REV | DATE     | BY | DESCRIPTION  |
|-----|----------|----|--|
| -   | 6-5-2013 | BS | NOTHING CHANGED, OLD REVISION C                            |
| A   | 6-1-2014 | BS | SCREW CAP DESIGN CHANGED, NEW NUMBER WITH O-RING: E0011674 |

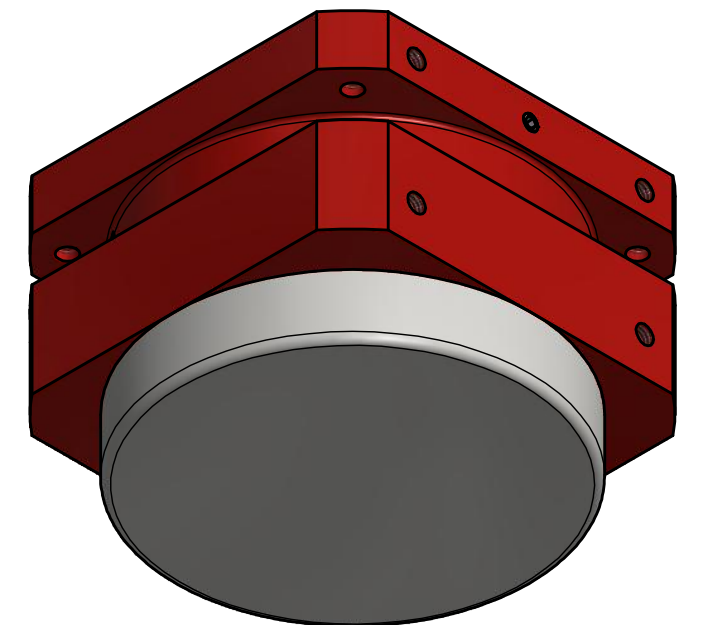
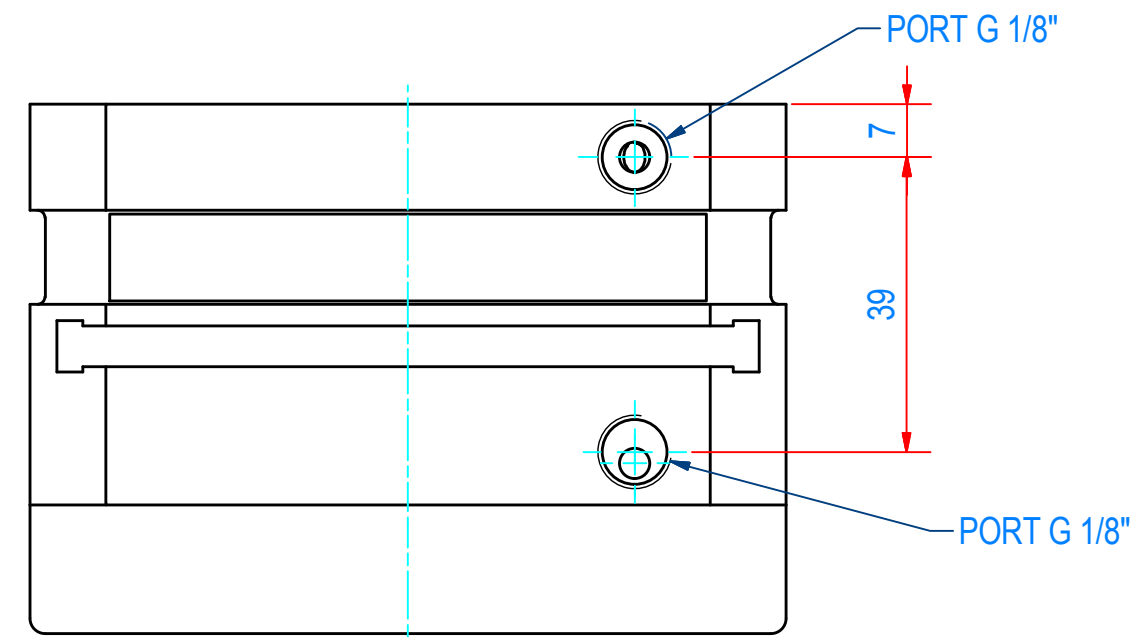
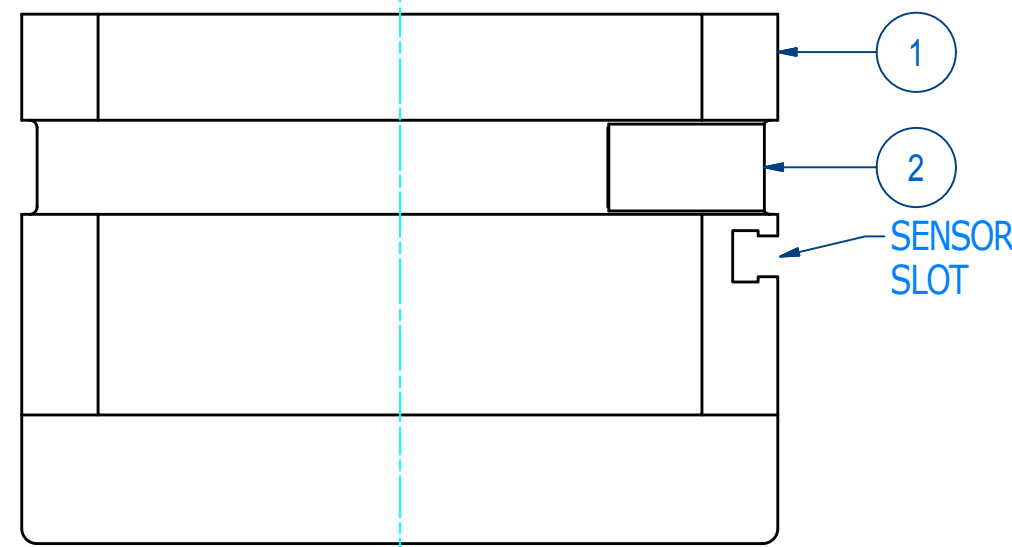
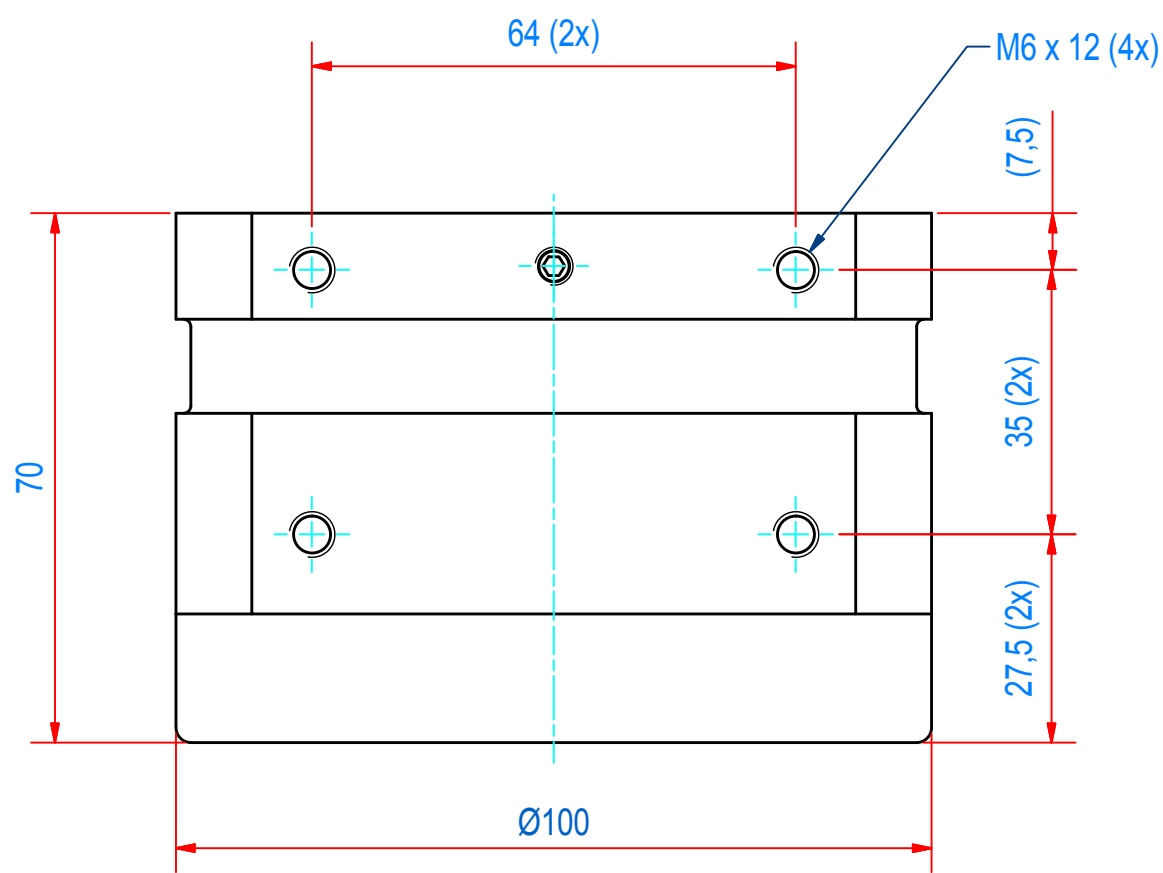
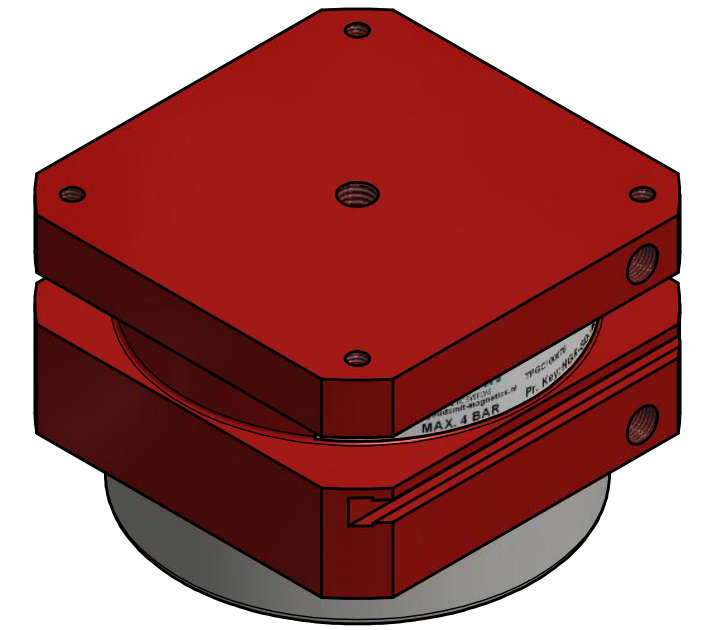
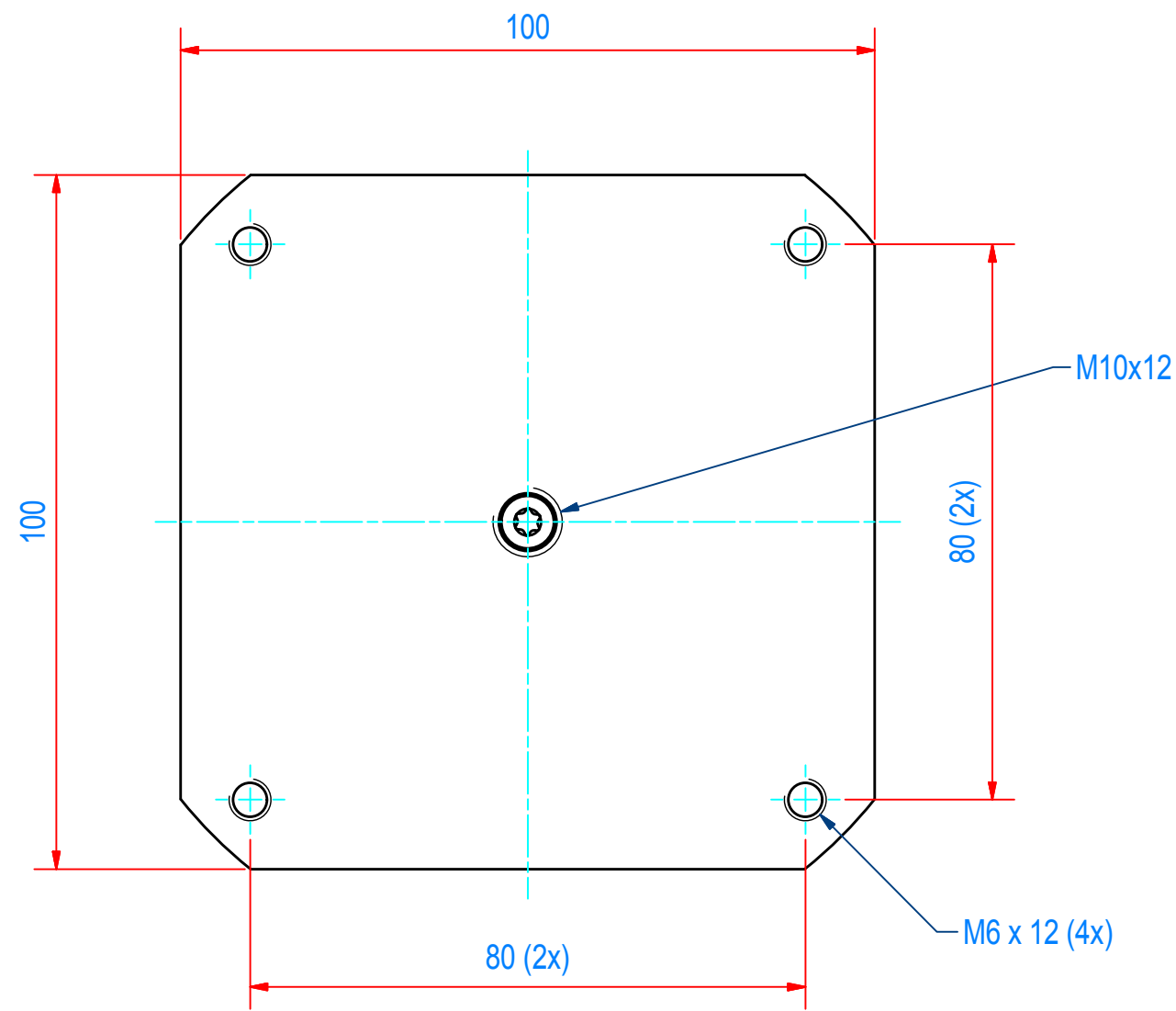

| ITEM     | QTY | PART NUMBER | DESCRIPTION        | Dimensions             |
|----------|-----|-------------|--------------------|------------------------|
| 2        | 1   | E0038028    | STICKER TPGC100078 |                        |
| 1        | 1   | E0011675    | MOUNTING ASSY      |                        |
| RAW MAT. | QTY | MAT. NUMBER | MAT. DESCRIPTION   | LENGTH (mm) WIDTH (mm) |
| 1        | 1   |             |                    |                        |

|                                  |  |   |
|----------------------------------|--|---|
| Sheet: A2                        | Extra info:  | General tolerance: ISO 2768- mK           |
| Drawn: BS                        | Weight (kg): 1,5   | Drawn according: ISO268; ISO1101; ISO2553 |
| Date: 6-5-2013                   |  | Status: Standard                          |
| Spare part: False                |  | Customer reference number:                |
| Quick search: TPGC100            | <br><small>© All rights reserved. Reproduction is not permitted without written permission of GOUDSMIT Magnetic Systems BV</small> | File number: TPGC100078 Rev: A            |
| Description: HGR-SQ-100-FL-R-G-S |  | Part number: TPGC100078 Rev: A            |